

DUMPSQUEEN

SOA Design & Architecture Lab

SOA S90.09

Version Demo

Total Demo Questions: 5

Total Premium Questions: 40

Buy Premium PDF

<https://dumpsqueen.com>

support@dumpsqueen.com

dumpsqueen.com

QUESTION NO: 1

The Client and Vendor services are agnostic services that are both currently part of multiple service compositions. As a result, these services are sometimes subjected to concurrent access by multiple service consumers.

The Client service is an entity service that primarily provides data access logic to a client database but also provides some calculation logic associated with determining a client's credit rating. The Vendor service is also an entity service that provides some data access logic but can also generate various dynamic reports.

After reviewing historical statistics about the runtime activity of the two services, it was discovered that the majority of concurrent runtime access is related to the processing of business rules. With the Client service, it is the calculation logic that is frequently required and with the Vendor service it is the dynamic reporting logic that needs to be accessed separately from the actual report generation.

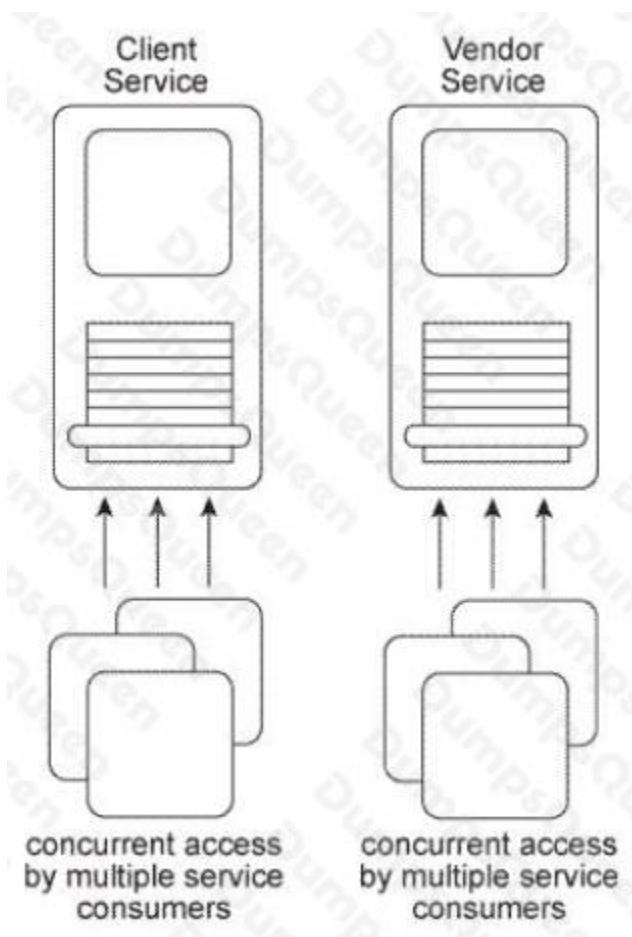

Currently, due to the increasing amount of concurrent access by service consumers, the runtime performance of both the Client and Vendor services has worsened and has therefore reduced their effectiveness as service composition members. What steps can be taken to solve this problem without introducing new services?

A. The Rules Centralization pattern can be applied by extracting the business rule logic from the Client and Vendor services and placing it into a new Rules service. This will naturally improve the runtime performance of the Client and Vendor services because they will no longer be subjected to the high concurrent access of service consumers that require access to the business rules logic.

B. The Redundant Implementation pattern can be applied to the Client and Vendor services, thereby establishing duplicate implementations that can be accessed when a service reaches its runtime usage threshold. The Intermediate Routing pattern can be further applied to provide load balancing logic that can, at runtime, determine which of the redundant service implementations is the least busy for a given service consumer request.

C. The Rules Centralization pattern can be applied together with the Redundant Implementation pattern to establish a scalable Rules service that is redundantly implemented and therefore capable of supporting high concurrent access from many service consumers. The Service Abstraction principle can be further applied to hide the implementation details of the Rules service.

D. None of the above.

ANSWER: B

QUESTION NO: 2

Service Consumer A sends a message to Service A (1), which then forwards the message to Service B (2). Service B forwards the message to Service C (3), which finally forwards the message to Service D (4).

Services A, B, and C each contain logic that reads the content of the message and, based on this content, determines which service to forward the message to. As a result, what is shown in the Figure is one of several possible runtime scenarios.

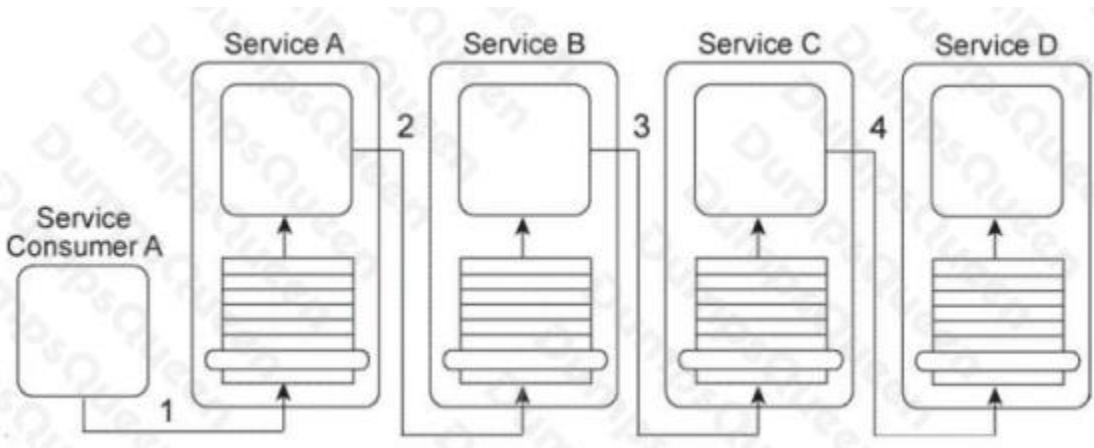

Currently, this service composition architecture is performing adequately, despite the number of services that can be involved in the transmission of one message. However, you are told that new logic is being added to Service A that will require it to compose one other service in order to retrieve new data at runtime that Service A will need access to in order to determine where to forward the message to. The involvement of the additional service will make the service composition too large and slow. What steps can be taken to improve the service composition architecture while still accommodating the new requirements and avoiding an increase in the amount of service composition members?

A. The Rules Centralization pattern can be applied to establish a centralized service that contains routing-related business rules. This new Rules service would replace Service B and could be accessed by Service A and Service C in order for Service A and Service C to determine where to forward a message to at runtime. The Service Composability principle can be further applied to ensure that all remaining services are designed as effective service composition participants.

B. The Asynchronous Queuing pattern can be applied together with the Rules Centralization pattern to establish a Rules service that encapsulates a messaging queue. This new Rules service would replace Service B and could be accessed by Service A and Service C in order for Service A and Service C to determine where to forward a message to at runtime. The

Service Composability principle can be further applied to ensure that all remaining services are designed as effective service composition participants.

C. The Intermediate Routing pattern can be applied together with the Service Agent pattern by removing Service B or Service C from the service composition and replacing it with a service agent capable of intercepting and forwarding the message at runtime based on pre-defined routing logic. The Service Composability principle can be further applied to ensure that all remaining services are designed as effective service composition participants.

D. None of the above.

ANSWER: C

QUESTION NO: 3

Service A is an orchestrated task service that is invoked by a separate composition initiator (1) and then sends a request message to Service C (2). Service C queries Database B to retrieve a large data record (3) and provides this data in a response message that is sent back to Service A. Service A temporarily stores this data in a central state database (4) and then sends a request message to Service D (5), which accesses a legacy system API to retrieve a data value (6). Service D then sends this data value in a response message back to Service A. The data in the state database is subsequently retrieved by Service A (7) and merged with the newly received data value. This combined data is written to Database A (8), which triggers an event that results in the invocation of Service B (9).

Service B is an orchestrated task service that sends a request message to Service D (10), which accesses a legacy system API to retrieve a data value (11) and then sends this data value in a response message back to Service B. Service B temporarily stores this data in a central state database (12) and then sends a request message to Service E (13), which performs a runtime calculation and then responds with the calculated data value back to Service B. The data in the state database is then retrieved by Service B (14) and merged with the calculated data value. Service B then uses the merged data to complete its business task.

The following specific problems and requirements exist:

- Database B uses a proprietary data format that is not compliant with the XML format used by all of the services in this service composition architecture. This incompatibility needs to be solved in order to enable the described service message exchanges.
- The service contract provided by Service D does not comply with the data model standards that were applied to the other services and therefore uses a different data model to represent the same type of data that is exchanged. This incompatibility needs to be solved in order to enable communication with Service D.
- Database B is a shared database that can be accessed by other services and applications within the IT enterprise, which causes unpredictable runtime performance. This performance problem needs to be solved in order to make the runtime behavior of Service C more predictable.
- For performance and maintenance reasons, Service A and Service B need to be deployed in the same physical environment where they can share a common state database.

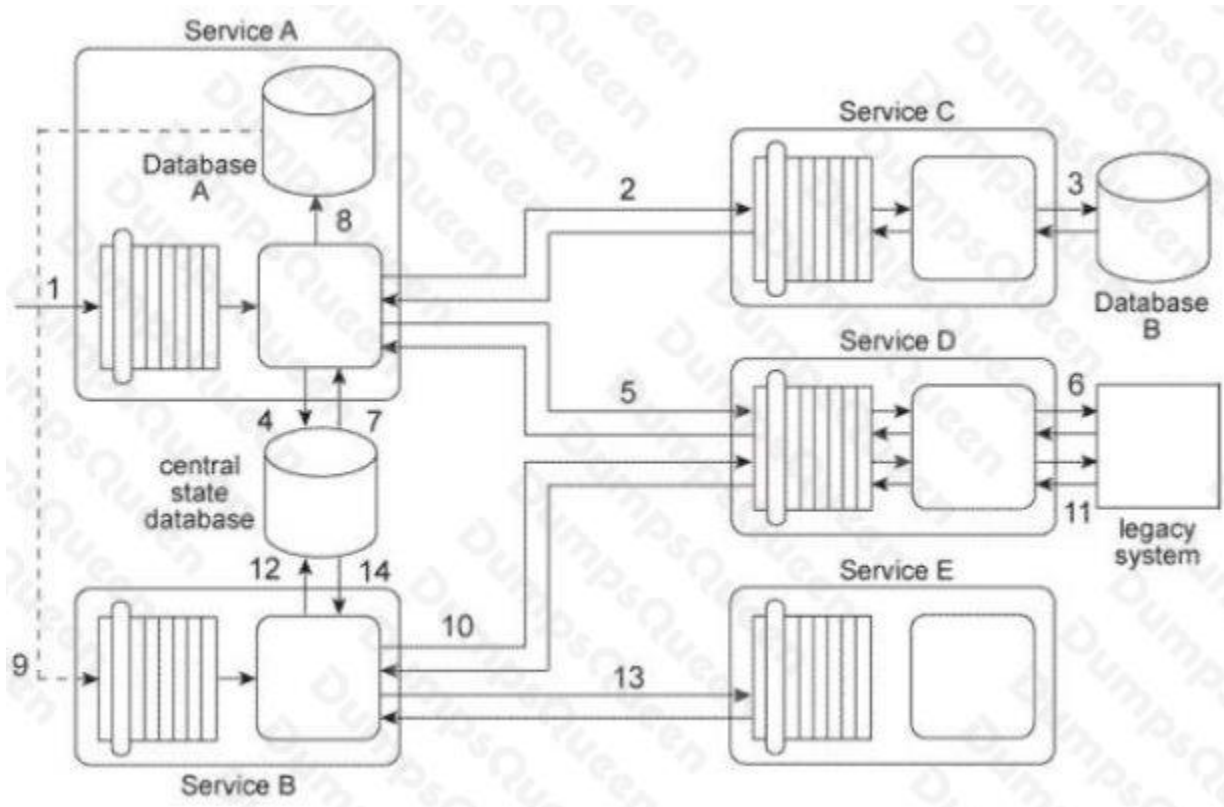

Upon reviewing these requirements it becomes evident to you that the Enterprise Service Bus compound pattern will need to be applied. However, there are additional requirements that need to be fulfilled. To build this service composition architecture, which patterns that is not associated with the Enterprise Service Bus compound pattern need to also be applied? (Be sure to choose only those patterns that relate directly to the requirements described above. Patterns associated with the Enterprise Service Bus compound pattern include both the required or core patterns that are part of the basic compound pattern and the optional patterns that can extend the basic compound pattern.)

- A. Atomic Service Transaction
- B. Compensating Service Transaction
- C. Data Format Transformation
- D. Data Model Transformation
- E. Event-Driven Messaging
- F. Intermediate Routing
- G. Policy Centralization
- H. Process Centralization
- I. Protocol Bridging
- J. Redundant Implementation
- K. Reliable Messaging
- L. Service Data Replication

M. State Repository

ANSWER: H L M

QUESTION NO: 4

The architecture for Service A displayed in the Figure shows how the core logic of Service A has expanded over time to connect to a database and a proprietary legacy system (1) and to support two separate service contracts (2) that are accessed by different service consumers.

The service contracts are fully decoupled from the service logic. The service logic is therefore coupled to the service contracts and to the underlying implementation resources (the database and the legacy system).

Service A currently has three service consumers. Service Consumer A and Service Consumer B access Service A's two service contracts (3, 4). Service Consumer C bypasses the service contracts and accesses the service logic directly (5).

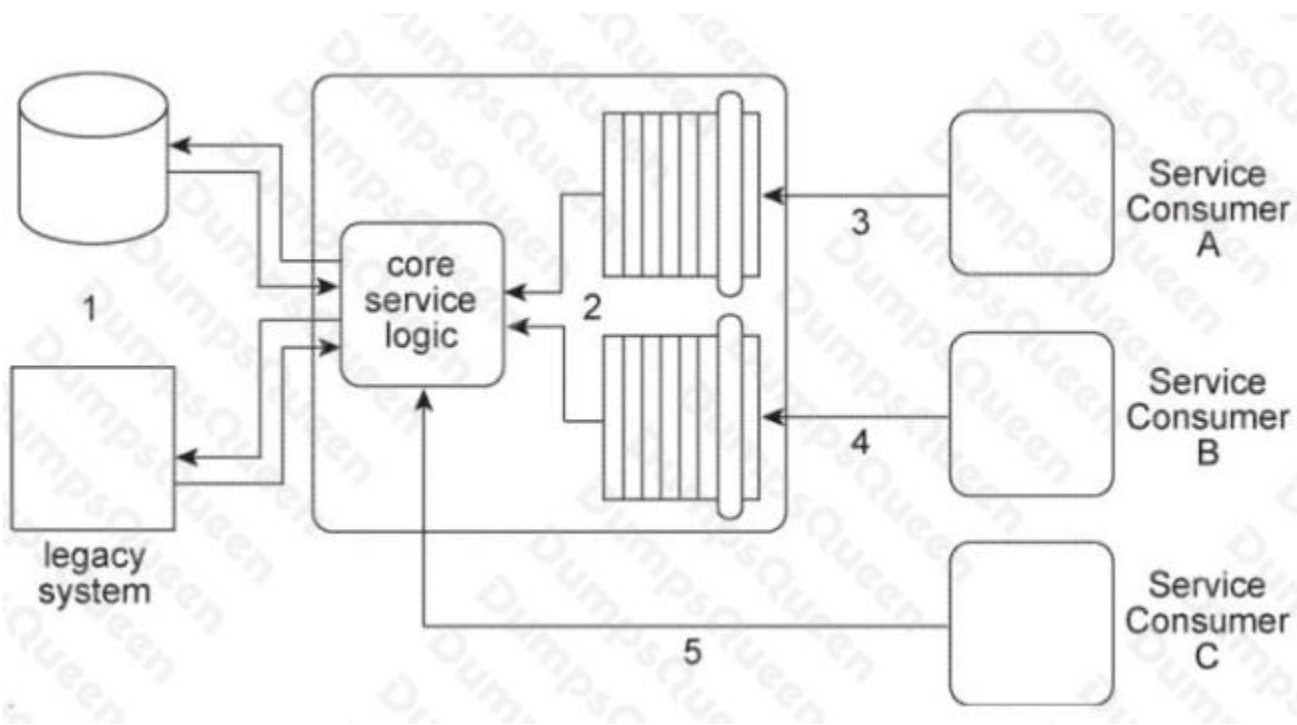

You are told that the database and legacy system that are currently being used by Service A are being replaced with different products. The two service contracts are completely decoupled from the core service logic, but there is still a concern that the introduction of the new products will cause the core service logic to behave differently than before. What steps can be taken to change the Service A architecture in preparation for the introduction of the new products so that the impact on Service Consumers A, B, and C is minimized?

A. The Service Abstraction principle can be applied to hide the implementation details from the core service logic of Service A, thereby shielding this logic from changes to the implementation. In support of this, the Service Facade pattern can be applied to position Facade components between the core service logic and Service Consumers A and B. These Facade components will be designed to regulate the behavior of Service A. The Contract Centralization pattern can be applied to force Service Consumer C to access Service A via one of its existing service contracts.

B. A third service contract can be added together with the application of the Contract Centralization pattern. This will force Service Consumer C to access Service A via the new service contract. The Service Facade pattern can be applied to

position a Facade component between the new service contract and Service Consumer C in order to regulate the behavior of Service A . The Service Abstraction principle can be applied to hide the implementation details of Service A so that no future service consumers are designed to access any of Service A's underlying resources directly.

C. The Service Facade pattern can be applied to position Facade components between the core service logic and the two service contracts. These Facade components will be designed to regulate the behavior of Service A . The Contract Centralization pattern can also be applied to force Service Consumer C to access Service A via one of its existing service contracts.

D. None of the above.

ANSWER: C

QUESTION NO: 5

Upon reviewing these requirements it becomes evident to you that the Orchestration compound pattern will need to be applied. However, there are additional requirements that need to be fulfilled. To build this service composition architecture, which patterns that is not associated with the Orchestration compound pattern need to also be applied? (Be sure to choose only those patterns that relate directly to the requirements described above. Patterns associated with the Orchestration compound pattern include both the required or core patterns that are part of the basic compound pattern and the optional patterns that can extend the basic compound pattern.)

A. Atomic Service Transaction

B. Compensating Service Transaction

C. Data Format Transformation

D. Data Model Transformation

E. Event-Driven Messaging

F. Intermediate Routing

G. Policy Centralization

H. Process Centralization

I. Protocol Bridging

J. Redundant Implementation

K. Reliable Messaging

L. Service Data Replication

M. State Repository

ANSWER: C L